

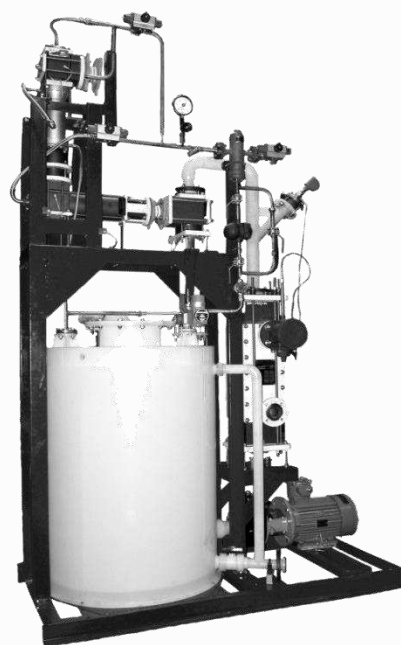

CEPIC

Anticorrosion since 1958

Assemblies and Systems





CEPIC

Anticorrosion since 1958



ABOUT CEPIC

2 & 3

INGENIERIE ET MATERIAUX

4

SULFURIC ACID DILUTION SKIDS

5

PUMPING, COOLING, HEATING SKID

6

VACUUM GENERATORS

7

GAS SCRUBBER VACUUM UNITS

8

OTHER INFORMATION

9



EXPERIENCE

Specialist since 1958 in the manufacture of anticorrosion chemical engineering equipment, CEPIC offers its customers a wide range of products:

- ✓ Centrifugal pumps in graphite and plastics
- ✓ Heat exchangers in impregnated artificial graphite, Carbonite®
- ✓ Systems and skids (dilution of H₂SO₄, treatment of HCl, ejectors, vacuum units)
- ✓ Made-to-specification machined parts in graphite
- ✓ Graphite rupture discs



EXPERTISE

Through our close collaboration with our clients, we have developed an incomparable amount of know-how in the field of hydraulic, thermal and mechanical sizing.

Our teams are therefore fully capable of designing and producing assemblies and systems that are adapted to our customers' needs.



SOLIDITY

Our equipment is manufactured in Normandy, in Saint Etienne du Rouvray, 120 km north-west of Paris.

Our recently-built factory has the highest-level technology for molding, impregnating, and machining, and our teams have extensive experience.

This combination of know-how and state-of-the-art technology allows us to produce safe systems and skids for applications involving the most corrosive fluids.



APPLICATIONS

CEPIC's systems and skids are used in a very wide variety of applications:

 Waste management  Chemicals

 Iron & Steel  Surface treatments

 Fertilizers  Pharmaceuticals

REACTIVITY

Our Engineers are always happy to discuss the sizing of your systems and skids in order to fully respond to your needs.

Our specific technical follow-up of systems and skids we install guarantees fast service when it comes to supplying spare parts, even several dozen years after the initial implementation.

COMPETENCES

Our engineering teams, with their significant experience in dimensioning of anticorrosion equipment, are also experts in sizing the processes that are associated with them. Aside from our industrial range of components, we are also able to provide you with complete systems and assemblies that are sized and designed to meet your specifications and restrictions.

OUR OFFER

Our teams handle the following aspects in designing and building your systems :

- Needs analysis
- Process sizing
- Thermal and energy analysis
- Preliminary and Definitive Pre-Project Definitions
- Study of the detailed specifications
- Purchase of “standard” components
- Sizing, conception and construction of the specific elements (pumps, exchangers, ejectors...)
- Production of the regulation and commands systems
- Assembly and testing in our workshops
- On-site fitting and start-up

MATERIALS

Our experience in the manufacture of anticorrosion equipment allows us to master the use of the following materials:

CARBONITE® :

An impregnated artificial graphite which can be used at temperatures of up to 170°C, presenting a low dilatation coefficient, considerable geometric stability, and an excellent resistance in most corrosive environments.

PVDF (Polyvinylidene Fluoride) :

Essential characteristics of this material: its thermoplasticity which makes it easy to use; its remarkable thermal stability at temperatures of between -50°C and +150°C; its mechanical resistance which is far superior to ordinary thermoplastics; its very good resistance to abrasion and its excellent resistance to most corrosive agents.

PP (Polypropylène) :

Frequently-employed anticorrosion material that is easy to use. Excellent mechanical resistance up to a temperature of 90°C; good resistance to acid and basic agents and some solvents.

PE (Polyéthylène) :

Excellent resistance to impact, even at very cold temperatures; good chemical resistance to acids and some solvents; usage temperatures from -50 to +80°C; very good resistance to abrasion.

PTFE (Polytétrafluoréthylène) :

Excellent chemical inertia; can be used at a temperature range of up to 120 or 150°C (either pure or charged). Its particular usage characteristics mean that this material must be reserved for specific applications.

FUNCTION

Continual, safe, and economical production of diluted sulfuric acid H_2SO_4 , from concentrated acid and water.

OUR OFFER

Calculation of the thermal balance of the specific dilution to define and optimize the choice of components

Separate components :

- ✓ Carbonite® and PTFE dilutors
- ✓ Carbonite® heat exchangers
- ✓ Centrifugal pumps, dispensers, pneumatic components

Compact dilution skids :

- ✓ All apparatus, connecting and skid pipes
- ✓ Cooling fluid management
- ✓ Regulation and safety
- ✓ On-site fitting and startup

ADVANTAGES

- ✓ Reduction in the intermediate reserves
- ✓ Reduced acid transport costs (only the acid concentrate needs to be transported)
- ✓ Rapidly operational dilution skid
- ✓ The diluted acid is delivered cold and thus can be used immediately.
- ✓ Flexible use with respect to a nominal flow rate.
- ✓ Possibility of varying the concentration and temperature of the diluted acid.

PRINCIPLE

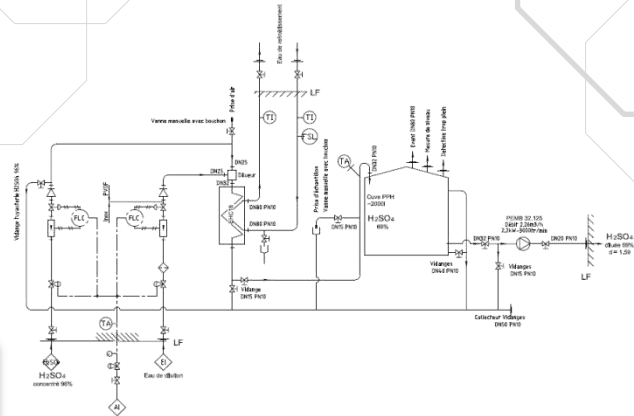

The concentrated acid is mixed with water in a specific device, called diluter. As this is an exothermic reaction the diluted acid needs to be cooled. This is done thanks to the CEPIC graphite heat exchanger.



CEPIC Sulfuric acid dilutor



Skid assembly for 98% sulfuric acid dilution; yields acid that is diluted at 40%

FUNCTION

Pumping, cooling or heating corrosive liquids (Hydrochloric acid HCl, Sulfuric acid H₂SO₄...).

PRINCIPLE

Comprehensive, ready-to-operate units comprised of a CEPIC corrosion resistant centrifugal pump, CEPIC Carbonite® heat exchanger, and additional fittings as per application requirements (vat, agitator, temperature gauge, flow gauge, level gauge...)

ADVANTAGES

- ✓ Vertical integration: CEPIC designs and manufactures all the main elements on the skid, including the group assembly
- ✓ Specifications for installation and use of each component on the skid are perfectly applied during the design phase of the skid

CAPACITIES

- ✓ Centrifugal pumps in Carbonite® or plastics, 1 m³/h - 700 m³/h
- ✓ Compact Carbonite® heat exchangers, 0.7 m² - 150 m²
- ✓ Standard or made-to-specification shakers, vertical or lateral installation

OUR OFFER

- ✓ Your needs analysis
- ✓ Component sizing and optimization
- ✓ Production of the pumps, heat exchangers, storage tanks...
- ✓ Setup assembly and fitting of the connecting pipes and skid
- ✓ Regulation and safety measures where required
- ✓ On-site fitting and startup



Agitator element



Pump skid with condenser

FUNCTION

A device or an assembly of static devices that permit the creation of a vacuum in a closed space, according to process requirements.

OUR OFFER

- ✓ Independent ejectors in Carbonite® or plastics (from DN 20 to DN 300)
- ✓ Ready-to-install vacuum units:
 - Component calculation and optimization
 - Production of the Ejectors
 - Production of the Carbonite® condensers
 - Setup assembly and fitting of the connecting pipes and skid
- ✓ Supply of the intermediate condensate recuperation units
- ✓ On-site fitting and startup

CAPACITIES

Gas flow: 2.5 kg/h to max 100 kg/h (air)
 Residual pressure up to 1 millibar
 Vapor flow: 55 g/h to max 800 kg/h
 Cooling water flow: 4 m³/h to max 42 m³/h

ADVANTAGES

- Resists corrosion perfectly
- Motor fluid: vapor or non-viscous liquids
- Temperature of fluid intake: up to 200°C
- Motor fluid pressure: up to 10 effective bars
- Possible installation in ATEX zones

PRINCIPLE

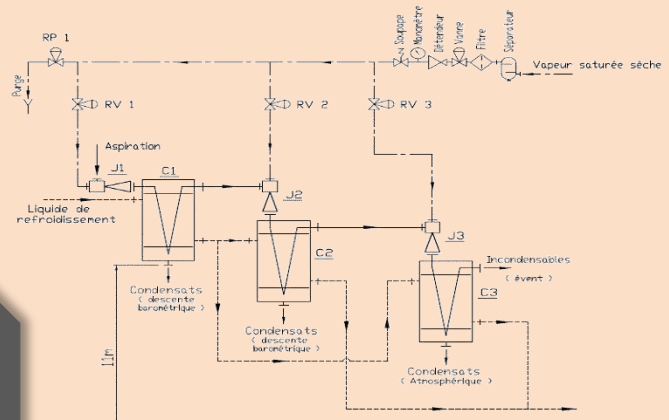

When the equipment requires a high rate of compression and the required intake pressure is less than about 150 mbars, a series of several ejectors is necessary.

Each ejector represents a level of the installation and is indicated by the level number. In most cases, to prevent the steam from decompressing to the value of the level before, the vapor has to be condensed upon ejection by one or more Carbonite® condensers.

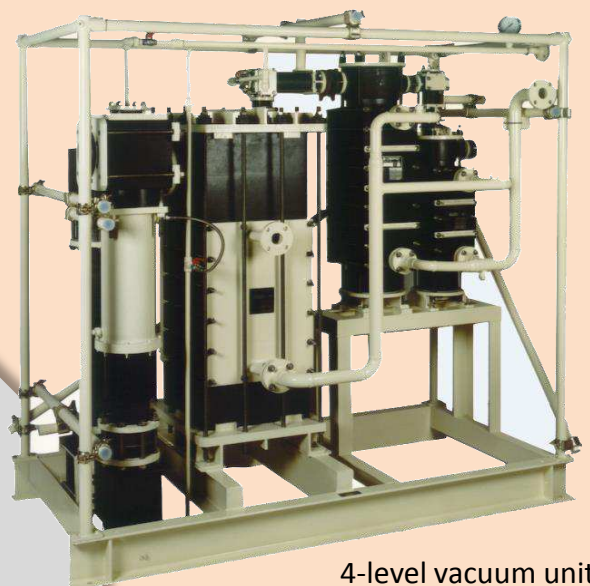

4-level vacuum unit
10kg/h = 1 Torr

FUNCTION

Ejector and hydro-ejector unit for the generation of a vacuum in the machine as per process requirements

PRINCIPLE

Serial fitting of one or more ejectors with a hydro-ejector allows high vacuums to be generated without pressure columns or an intermediate recuperation unit.

The use of hydro-ejectors neutralizes the extracted gases by condensing them or absorbing them with the engine liquid.

If necessary, a Carbonite® cooling unit can be inserted into the series to prevent temperature increases.

Gas scrubber vacuum generator assembly with Carbonite® ejectors and CEPIC anticorrosion centrifugal pump

OUR OFFER

- Your needs analysis
- Component calculation and optimization
- Production of the ejectors, hydro-ejectors, pumps, heat exchangers, storage tanks...
- Setup assembly and fitting of the connecting pipes and skid
- Regulation and safety measures where required
- On-site fitting and startup

CAPACITIES

- Ejectors produced in Carbonite® or plastics (PP, PE, PVDF)
- PP, PEHD, PVDF tanks
- CEPIC Centrifugal pumps in Carbonite®, PP, PE, PVDF or PTFE.
- Can be built for ATEX 94/9/CE zones

ADVANTAGES

- ✓ Perfect resistance to corrosion
- ✓ Standard or built-to-specification skids
- ✓ Space requirements adapted to your needs
- ✓ Integration of CEPIC-produced components for a reliable and economical offer.



445 rue Noyer des Bouttières Saint Etienne du Rouvray

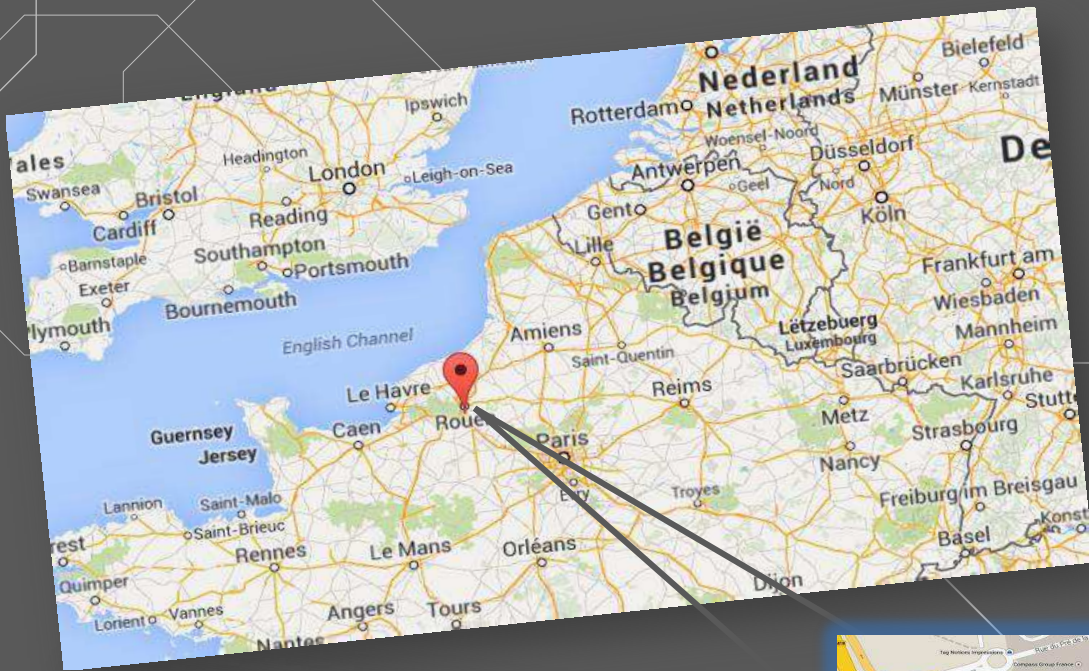

By car Paris, Highway A13, exit 22.
By train from St Lazare -> Oissel

Other CEPIC equipment available:

- Anticorrosion centrifugal pumps in Carbonite® or plastics,
- Systems and skids (dilution of H₂SO₄, treatment of HCl, ejectors, vacuums
- Standard or made-to-specifications stirrers and shakers
- Machined to specification graphite parts
- Carbonite® rupture discs





CEPIC

Anticorrosion since 1958



Agent/Distributor :

